



2007 IPA Osaka Silver Congress Exhibit Space for Commercial Companies

The International Psychogeriatric Association (IPA), the Japanese Psychogeriatric Society (JPS), and the Japanese Society for Dementia Research (JSDR) thank you for your interest in exhibiting at the 2007 IPA Osaka Silver Congress in Osaka, Japan, 14-18 October 2007. This year's Congress – our 13th International Congress - will officially celebrate IPA's 25th Anniversary. IPA is proud to work with JPS and JSDR as we look to welcome over 1500-2000 scientists, clinicians, and educators to Osaka. By exhibiting at this historic meeting, you are certain to meet with the recognized leaders in the Psychogeriatric field.

We hope you will join us in the celebration!

Exhibitor Information

Congress and Exhibition Organizer

Congress Corporation has been appointed the official congress and exhibition organizer. Please contact Congress Secretariat directly for information regarding exhibition and registration.

Congress Secretariat

c/o Congress Corporation
Congress Bldg., 3-6-13 Awajimachi
Chuo-ku, Osaka 541-0047, Japan
Tel: +81-6-6204-1330 Fax: +81-6-6229-2556
Email: ipa2007osaka@congre.co.jp

Venue

The venue of the exhibition is the event hall on the 3rd floor in the **Osaka International Convention Center (OICC)**.

Since its establishment in 2000, the Osaka International Convention Center (OICC) has served as a grand gate open widely to the world. It is located in Nakanoshima, the urban center of Osaka, which has been known as the center of cultural and economic exchanges since ancient times. A well-developed access network, coupled with sophisticated urban functions, make Nakanoshima an ideal venue for people of the world to meet together and deepen mutual understanding. To view the Osaka International Convention Center, please visit <http://www.gco.co.jp>

The event hall is a 1,900 square-meter room with a 9.4 meter-high ceiling and has no obstructing pillars, which creates a great sense of openness. In addition to exhibit space, free poster presentations and coffee breaks will also take place in the Exhibit Hall.

Exhibition Dates and Times

Exhibitor Set-up	Sunday 14 October	13:00-21:00
Opening Ceremony / Welcome Reception	Sunday 14 October	17:30-21:30
Exhibitor Hours	Monday 15 October – Thursday 18 October	09:30-16:45
Exhibitor Breakdown	Thursday 18 October	16:45-21:00

Exhibition Booth Rental and Fees

IPA offers three types of exhibitor packages. Package rental (rental of two types of exhibition booths) and Publisher's Browse Table.

Rental Fees

Package rental (Type A)	350,000 JPY/booth
Package rental (Type B)	100,000 JPY/booth
Publisher's Browse Table	25,000 JPY/title
Free Literature Table	No charge - special conditions apply

Package Type A

A Type-A booth measures 3,000 mm in width, 3,000 mm in depth, and 2,500 mm in height. The package includes: a back panel (3,000 mm in width and 2,500 mm in height); side panel (3,000 mm in depth and 2,500 mm in height); a company name plate (900 mm in width and 200 mm in height) mounted on the back panel; a 40W fluorescent lamp; and free 10 exhibitor badges. Additional exhibit badges are available for 5,000 JPY/badge.

One booth is available in the Type A package. If space permits, Type A exhibitors have the option to purchase one additional 3000 mm x 3000 mm booth. IPA will inform exhibitors on or before **25 June 2007** whether additional space will be available for purchase.

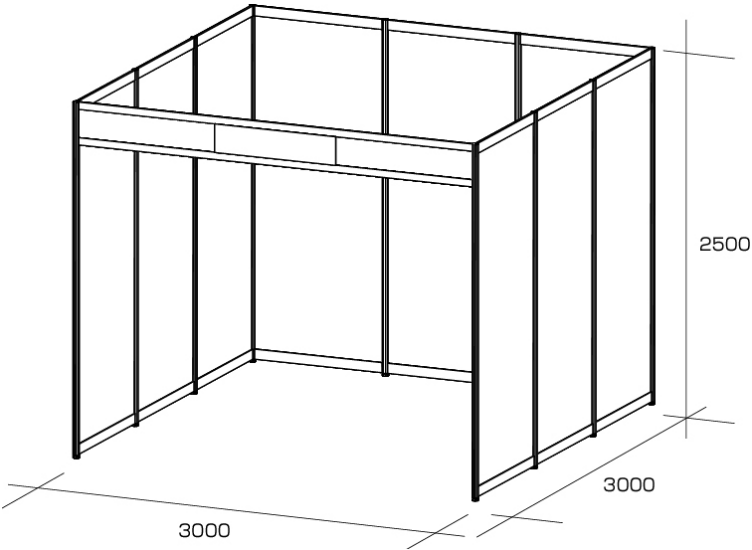

Package Type B

A Type-B booth measures 1,800 mm in width, 1,800 mm in depth, and 2,400 mm in height. The package includes: a back panel (1,800 mm in width and 2,400 mm in height); an exhibition platform (1,800 mm in width, 600 mm in depth, and 700 mm in height); a company name plate (900 mm in width and 200 mm in height) mounted on the back panel; a 40W fluorescent lamp; and free 4 exhibitor badges. Additional exhibit badges are available for 5,000 JPY/badge.

One booth is available in the Type B package. If space permits, Type B exhibitors have the option to purchase one additional 1800 mm x 900 mm booth. IPA will inform exhibitors on or before **25 June 2007** whether additional space will be available for purchase.

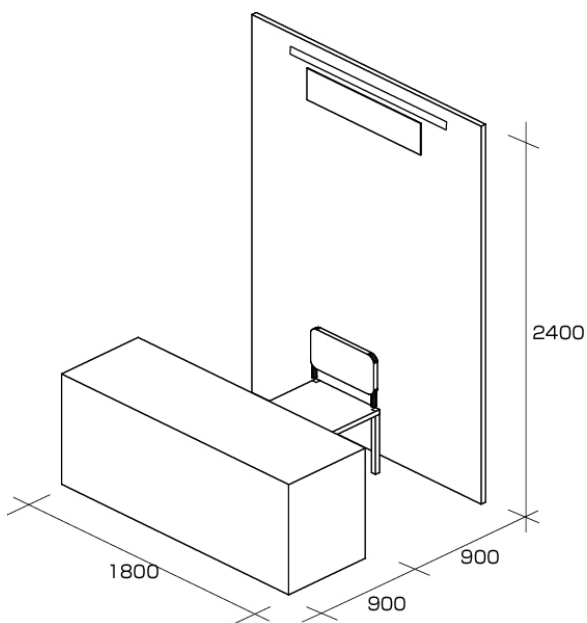

Publisher's Browse Table

For publishers who are unable to exhibit at the Congress, IPA offers the opportunity to exhibit their publications for display at a reduced rate. For 25,000 JPY per title, publishers can display their publications, literature, and order forms on the Publisher Browse table, located in the exhibit hall. The table **will** be staffed by IPA volunteers during exhibit hours.

Browse Table exhibitors may not congregate in the exhibit area and have no exhibit privileges other than the display of their materials. No canvassing or soliciting will be permitted. Violation will result in removal from the exhibit hall without refund.

Free Literature Table

An unstaffed Free Literature Table will be available to organizations who cannot exhibit. Acceptable materials for inclusion on the Free Literature table include meeting announcements, society materials, and publisher literature. No pharmaceutical or product literature will be displayed on the Free Literature Table.

All material to be considered for inclusion on the free literature table **must** be approved by IPA prior to the Congress.

Application Submission

To get the "Exhibitor Application Form" and additional information, please visit the Congress web site at <http://www.congre.co.jp/ipa2007>.

All Exhibitor Booth Applications should be submitted via fax to the Congress Secretariat until 31 July 2007.

General Information

Payment

Payment in full is due by **31 July 2007**. **If booth space is not paid in full by this date, IPA cannot guarantee space will be held.**

Contract Acceptance

IPA retains the right to refuse or deny any application submitted for this event, in which case it shall refund the exhibit fee. The IPA shall not be deemed to have approved an application until it has both deposited the exhibit fee and returned a confirmation letter.

The Exhibitor agrees to comply with the terms and conditions of the Exhibitor Prospectus and such other terms and conditions as the IPA, Congress Corporation and the OICC may impose at any time. The IPA reserves the right, at any time and without liability to the Exhibitor or anyone else to withdraw its approval of an application or to require the Exhibitor to vacate the exhibit site for just cause (which includes, but is not limited to, violation of any of the rules and conditions or interference with neighboring exhibits or the conference activities).

Space Assignments

Exhibit space will be assigned in order of receipt of applications and payment. Preferential assignment will be made to companies sponsoring the Congress. Due to the large number of companies offering similar or related product lines, the IPA Congress Exhibition Committee will make every effort but cannot guarantee that a supplier exhibiting similar products or a competitor will not be located in a nearby or adjoining exhibit space.

The organizer will have the right in its sole discretion to decide the allocation of booths in consideration of the nature of exhibits and the number of booths. Exhibitors cannot raise an objection against the decision by the organizer. Also, exhibitors are not allowed to assign or exchange all or part of their booths without the prior permission of the organizer.

Booth Staffing

It is expected that the exhibit booth will be staffed at all times during regular exhibit hours.

Conflict of Interest

We ask that Vendors or Exhibitors extend a professional courtesy to the IPA and not schedule outside activities for Congress Participants (such as golf outings, tours, or other special events) during Congress hours or any official Congress sponsored events. Only individuals wearing IPA Congress Badges will be permitted to Congress Sessions and the Exhibition Hall.

Booth Cancellation Policy

In the event that the Exhibitor cancels its reservation of space, and does so on or before 1 June 2007, the IPA will refund the exhibitor fee. Cancellations received after 1 June 2007 and on or before 10 August 2007 will receive a refund of the exhibitor fee less a 10,000 JPY Administrative Fee. There will be no refunds given after 10 August 2007.

The IPA reserves the right to reconfigure exhibit space as necessary to avoid empty spaces. If the IPA cancels the Congress for reasons other than force majeure, the IPA shall refund the exhibitor fee. In the event that the Congress is postponed or canceled for reasons beyond the control of IPA (force majeure, including but not limited to actions taken by the OICC, or acts of God) the IPA will either refund the exhibitor fee or provide equivalent space at the rescheduled event.

Exhibitor Installation and Dismantling

Exhibitor move-in is tentatively scheduled for Sunday, 14 October 2007 and dismantling for Thursday, 18 October 2007. Further information will be provided by Congress Corporation prior to the event. Exhibits must be on display with company representatives during the scheduled exhibit hours.

Hotel Accommodations

IPA has reserved sleeping rooms at various hotels near the convention center for the IPA 2007 Osaka Silver Congress. To reserve hotel rooms, please visit the Congress website at <http://www.congre.co.jp/ipa2007>.